

DC Start Directional Coupler

Model DC20-085 Rev.A

DC-8.5GHz 20dB High Directivity Directional Coupler

Micable DC20-085 can work at DC-8.5GHz. It has very accurate coupling over 0.5-8.5GHz and repeated consistent coupling below 0.5GHz. It is ideal for test instrument, wideband signal sampling and power monitoring

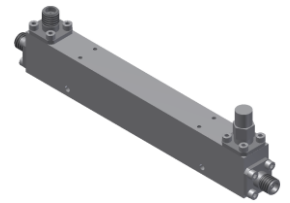

Specifications

All specifications are subject to change without notice at any time

Frequency Range	GHz	DC-0.3	0.3-0.5	0.5-8.5
Input VSWR	:1 (Typ./Max.)	1.1/1.3	1.1/1.3	1.1/1.3
Thru. VSWR	:1 (Typ./Max.)	1.1/1.3	1.1/1.3	1.1/1.3
Coupling VSWR	:1 (Typ./Max.)	1.1/1.3	1.1/1.3	1.1/1.3
Insertion Loss	dB(Typ./Max.)	0.2/0.5	0.2/0.5	0.4/0.8
Coupling	dB(Typ./Max.)	35/-	22/-	20/20±1.2
Directivity	dB(Typ./Min.)	25/-	25/-	25/20
Power ¹	W(Max.)	CW: 30; Peak: 3000		
Weight	g(Max.)	90	Dimension ²	mm 111.8x12.7x17.8
Interface	Main line: SMA [F], Coup.: SMA [F]; Stainless steel connector, Per IEC 61169			
Finishing	Nickel plating, Per QQ-N-290			
Temperature	Operating: -55--+85°C; Storage: -55--+100°C			
Environmental	Optional: Per MIL-STD-202F (contact supplier for detail info.)			
Eng. Customized	N/A			

Note:

1. VSWR ≤1.2 required for CW

2. Unless otherwise specified, Decimal tolerance: x±1; .x±0.5; .xx±0.1

Outline Drawing

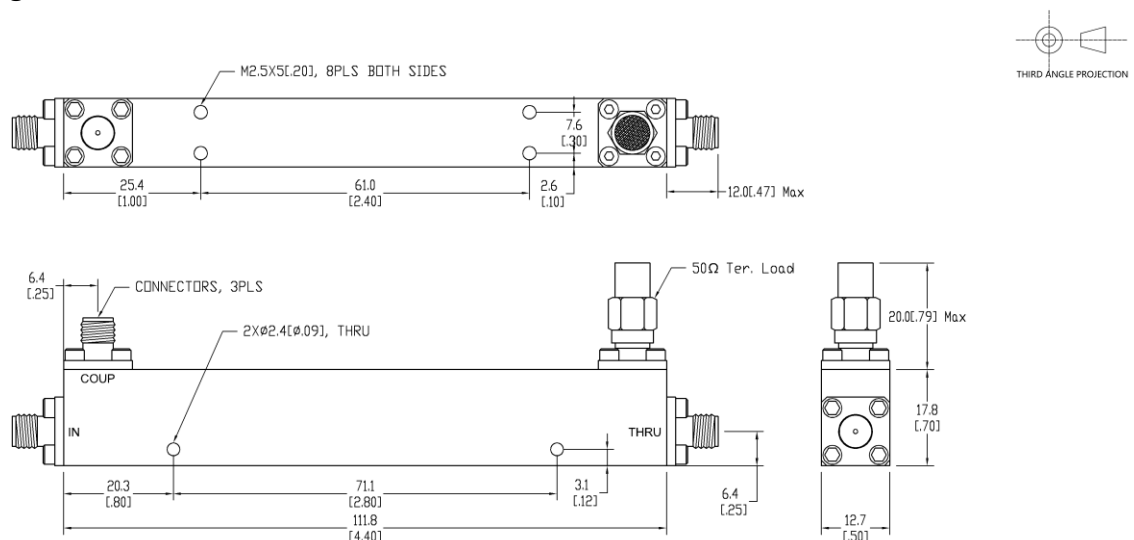

DC Start Directional Coupler

Model DC20-085 Rev.A

DC-8.5GHz 20dB High Directivity Directional Coupler

Typical Graph

@ Ambient Temperature

