

# Power Divider/Combiner

## Model P10N020180 Rev.B

2-18GHz 10-Way Power Divider/Combiner, Coaxial connector

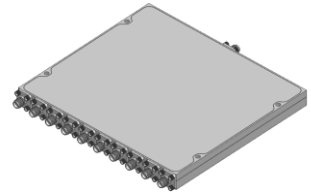

### Specifications

All specifications are subject to change without notice at any time

Frequency Range	GHz	2-8	8-18
Sum VSWR	:1 (Max.)	1.5	1.6
Distri. VSWR	:1 (Max.)	1.6	1.6
Insertion Loss <sup>1</sup>	dB(Max.)	1.7	2.8
Amp. Unbalance	dB(Max.)	±0.6	±0.8
Phase Unbalance	Deg. (Max.)	±7	±9
Isolation	dB(Min.)	16	18
Power <sup>2</sup>	W(Max.)	CW: FOR 30, REV 5; Peak: 3000	
Weight	g(Max.)	730	Dimension <sup>3</sup> mm (LxWxH) 132.0x147.7x12.7
Interface	Sum: SMA [F], Distri.: SMA [F]; Stainless steel connector, Per IEC 61169		
Finishing	Alloy iridite, Per MIL-DTL-5541F		
Temperature	Operating: -55~+85°C; Storage: -55~+100°C		
Environmental	Optional: Per MIL-STD-202F (contact supplier for detail info.)		
Eng. Customized	N/A		

- Note:
- Above Theoretical Loss 10dB
  - VSWR ≤ 1.2 required for forward CW; Amp. & phase unbalance required for reversed input signals
  - Unless otherwise specified, Decimal tolerance: x.±1; .x±0.5; .xx±0.1

### Outline Drawing

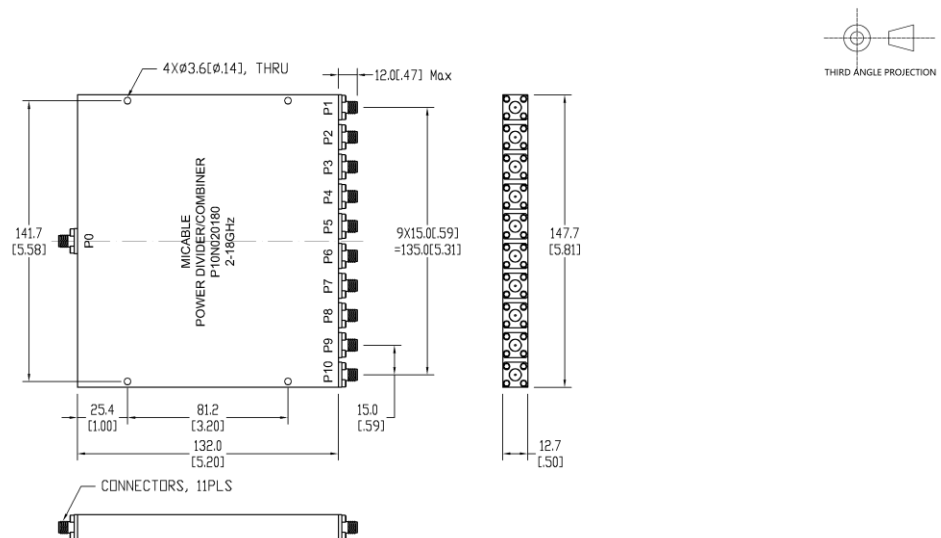

# Power Divider/Combiner

## Model P10N020180 Rev.B

2-18GHz 10-Way Power Divider/Combiner, Coaxial connector

### Typical Graph

@Ambient Temperature

