

Power Divider

Model P02T00500300 Rev.C

0.5-3GHz 2-Way Power Divider, Coaxial connector



Specifications

All specifications are subject to change without notice at any time

Frequency Range	GHz	0.5-3	
Sum VSWR	:1 (Max.)	1.3	
Distri. VSWR	:1 (Max.)	1.2	
Insertion Loss ¹	dB(Max.)	0.6	
Amp. Unbalance	dB(Max.)	±0.2	
Phase Unbalance	Deg. (Max.)	±3	
Isolation	dB(Min.)	20	
Power ²	W(Max.)	CW: FOR 30, REV 1; Peak: 500	
Weight	g(Max.)	50	Dimension ³ mm (LxWxH) 58.4x30.0x12.7
Interface	Sum: SMA [F], Distri.: SMA [F]; Stainless steel connector, Per IEC 61169		
Finishing	Sand blast		
Temperature	Operating: -40~+70°C; Storage: -55~+85°C		
Environmental	N/A		
Eng. Customized	N/A		

- Note:
- Above Theoretical Loss 3dB
 - VSWR ≤ 1.2 required for CW
 - Unless otherwise specified, Decimal tolerance: x±1; .x±0.5; .xx±0.1

Outline Drawing

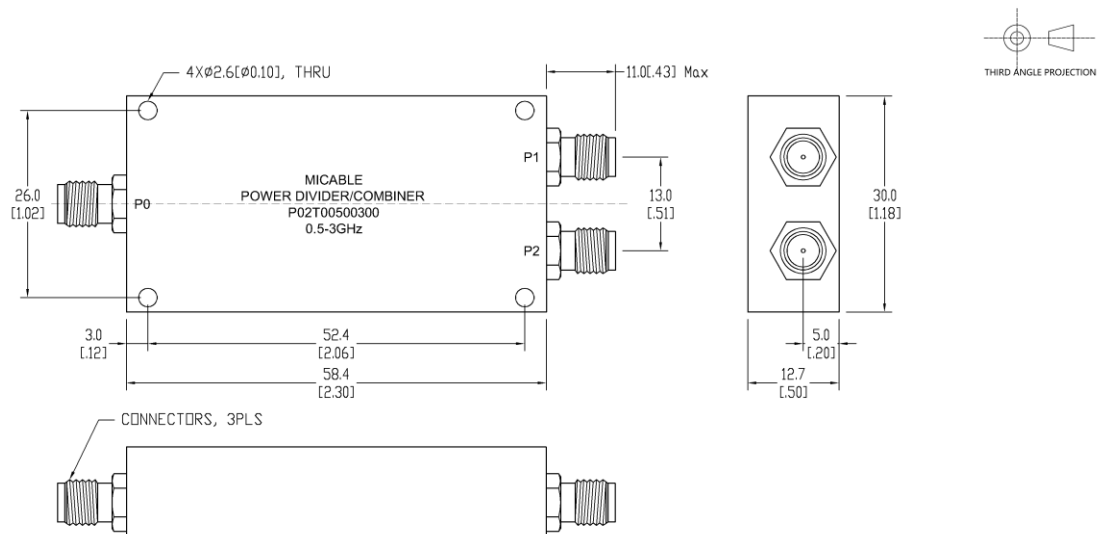

Power Divider

Model P02T00500300 Rev.C

0.5-3GHz 2-Way Power Divider, Coaxial connector

Typical Graph

Typical test environment: 25°C and 60%RH

